

## Testing Printed Circuit Boards for Creep Corrosion in Flowers of Sulfur Chamber

Haley Fu  
iNEMI, Shanghai, China

Prabjit Singh, Levi Campbell and Jing Zhang  
IBM Corporation, Poughkeepsie, NY, USA

Wallace Ables  
Dell Corporation, Austin, TX, USA

Dem Lee and Jeffrey Lee  
iST-Integrated Service Technology, Inc., Taiwan

Jane Li and Solomon Zhang  
Lenovo (Beijing) Limited Corporation, Beijing, China

Simon Lee  
The Dow Chemical Company, Tao Yuan Hsien, Taiwan

### Abstract

The iNEMI technical subcommittee on creep corrosion is developing a flowers-of-sulfur (FOS) based qualification test for creep corrosion on printed-circuit boards (PCBs). The test setup consists of a 300-mm cube chamber with two means of mounting the test specimens and flowing air over them to expose them to constant, predefined humidity and temperature conditions and sulfur and other contaminants. The FOS chamber performance has been evaluated using copper and silver foils and preliminary test runs have been conducted on PCBs from a manufacturing lot known to have failed in service. The effect of air velocity on the copper and silver corrosion rates was quite linear. The effect of humidity on copper and silver corrosion rates in the low air velocity range of less than 0.1 m/s showed a strong dependence on relative humidity. In the high velocity range of 1 m/s, there was no clear dependence of humidity on copper and silver corrosion rates. A means has been developed for applying controlled concentration of ionic contamination on selected local areas of test PCBs. Preliminary test runs have shown that ionic contamination found in fine dust may be a necessary condition for copper creep corrosion. Printed circuit boards from a manufacturing lot that suffered creep corrosion in service, with and without dust contamination applied to them, were tested in a FOS chamber at 60°C with 1 m/s air flowing over them. The PCBs with no dust contamination did not suffer creep corrosion in the 3-day test; whereas, the PCBs with dust contamination suffered creep corrosion with morphology similar to that occurring in the field.

### Introduction

Qualification of electronic hardware from a corrosion resistance standpoint has traditionally relied on stressing the hardware in a variety of environments. Before the development of tests based on mixed flowing gas (MFG), hardware was typically exposed to temperature-humidity cycling. In the pre-1980s era, component feature sizes were relatively large. Corrosion, while it did occur, did not in general degrade reliability. There were rare instances of the data center environments releasing corrosive gases and corroding hardware. One that got a lot of publicity was the corrosion by sulfur-bearing gases given off by data center carpeting. More often, corrosion was due to corrosive flux residues left on as-manufactured printed circuit boards (PCBs) that led to ion migration induced electrical shorting. Ion migration induced failures also occurred inside the PCBs due to poor laminate quality and moisture trapped in the laminate layers.

The two common modes of environmentally induced corrosion related failures electronic hardware is currently suffering are the corrosion of silver terminated surface mount resistors and the creep corrosion on printed circuit boards (PCBs). The corrosion of silver terminations in surface mount resistors has been brought largely under control by improving the packaging of the resistors and by developing a flowers of sulfur test consisting of exposing the resistors to dry flowers of sulfur in a chamber at 105°C for 20 days. The flowers of sulfur chamber is kept dry by not intentionally introducing moisture in to the chamber; the reason for introducing no moisture is that silver corrosion has little dependence on humidity and, anyway, adding and controlling humidity to a chamber at 105°C would be problematic.

**Table 1: MFG test conditions developed/used by various organizations. For organizations with multiple test conditions, only the most aggressive condition is listed here.**

Organization	Reference	Temp (°C)	RH (%)	H <sub>2</sub> S (ppb)	Cl <sub>2</sub> (ppb)	NO <sub>2</sub> (ppb)	SO <sub>2</sub> (ppb)	Cu corrosion rate, nm/day
Battelle Columbus	Abbott 1988	50!2	75!2	200!10	50!5	200!25	--	--
Rockwell Automation	Veale 2005	28.5!0.5	75	100	20	200	200	350
Alcatel-Lucent	Xu 2009	40	69	1700	20	200	200	600
Univ of Maryland	Zhang 2010	32!1	75!1	1050!50	--	--	--	--
iNEMI	Fu 2011, Fu 2012	40	70-75%	1200	20	200	200	500

The creep corrosion of PCBs is commonly believed to be mostly on RoHS compliant circuit boards [Fu 2011]. RoHS is the European Union Restriction of Hazardous Substance (RoHS) directive issued in February 2003 that took effect on 1 July 2006, banning the use of lead in solder joints [ROHS 2003]. The silver and copper containing tin solder that replaced the lead tin (PbSn) solder has two shortcomings: One is its higher melting range that necessitates the change of PCB laminate epoxies to ones with higher glass transition temperatures; the second is the generally poorer wetting/spreading on the copper metallization of the PCBs by the lead free solder. The net result is that the RoHS compliant PCBs are more prone to creep corrosion. Creep corrosion is the corrosion of the copper (and sometimes silver) metallization on PCBs and the creeping of the corrosion product (mostly sulfides of copper and sometimes silver) on the board surfaces which may lead to the electrically shorting of neighboring features on PCBs. The problem of creep corrosion has been largely brought under control by selecting finishes, by trial and error, that have less propensity to creep corrosion. But the challenge of a reliable qualification test for creep corrosion remains, though some progress has been made developing the mixed flowing gas (MFG), the Chavant clay and the flowers of sulfur tests.

Before we discuss the tests for the qualification of creep corrosion, let us briefly examine the three gases (H<sub>2</sub>S, NO<sub>2</sub> and Cl<sub>2</sub>) considered to have the most influence on the corrosion of copper and silver [Abbott 1988].

H<sub>2</sub>S: Hydrogen sulfide is a colorless gas with a rotten-egg odor. Some can smell hydrogen sulfide at levels as low as 0.5 parts per billion (ppb). Most hydrogen sulfide in the air comes from natural sources. It is produced when bacteria break down plant and animal matter, often in stagnant waters with low oxygen content such as bogs and swamps. Volcanoes, hot springs and underwater thermal vents also release hydrogen sulfide. Industrial sources of hydrogen sulfide include petroleum and natural gas extraction and refining, pulp and paper manufacturing, rayon textile production, chemical manufacturing and disposal of construction and demolition debris contain large quantities of wallboard [NY State Dept of Health 2013].

NO<sub>2</sub>: Nitrogen dioxide belongs to the NO<sub>x</sub> family of highly reactive gases that are generated when fuel is burned at high temperatures in motor vehicles, stationary sources such as electric utilities and industrial boilers. A suffocating, brownish gas, NO<sub>x</sub> is a strong oxidizing agent that reacts in the air to form corrosive nitric acid, as well as toxic organic nitrates [EPA 2013].

Cl<sub>2</sub>: Chlorine is among the ten highest volume chemicals manufactured. It is produced commercially by electrolysis of sodium chloride brine. Chlorine is used to disinfect water and is part of the sanitation process for sewage and industrial waste. During the production of paper and cloth, chlorine is used as a bleaching agent. It is also used in cleaning products, including household bleach which is chlorine dissolved in water. Chlorine is also used in the preparation of chlorides, chlorinated solvents, pesticides, polymers, synthetic rubbers, and refrigerants.

Mixed flowing gas test is the most researched test for the study of atmospheric corrosion of copper. The major development of the test and the definition of the performance characteristics of the test occurred at Battelle-Columbus in the 1980s [Abbott 1988]. According to this study, the commonly occurring gases that have the most influence on copper corrosion were found to be H<sub>2</sub>S, Cl<sub>2</sub> and NO<sub>2</sub>. Sulfur dioxide, SO<sub>2</sub>, a common contaminant in most industrially polluted environments, was not considered to be corrosive to copper. Creep corrosion of copper on porous Au-Ni-Cu plating was found to be accelerated by small amounts of NO<sub>2</sub>, but large variations in concentration had little added effect. During the early 1980s, PCBs were soldered with PbSn solder and therefore did not suffer creep corrosion. The Battelle-Columbus study had no reason to address creep corrosion on PCBs.

The need for a reliable qualification test for copper creep corrosion on PCBs was highlighted by a 2007 publication from Dell Incorporated with the surprising observation that immersion silver (ImAg) finished PCBs, that had passed a battery of tests, such as HALT, shock and vibration, torsion and thermal cycling, failed in the field due to creep corrosion, some within 4 weeks of being put into service [Schueller 2007]. The field experience was especially surprising because earlier in 2004, a

typical MFG test at Underwriters Laboratories on PCBs with immersion silver had not shown any evidence of creep corrosion [Cullen 2004].

One of the most cited early work on PCB creep corrosion testing in MFG environment was done at Rockwell Automation [Veale 2005]. The MFG gas composition and temperature and humidity condition was able to cause creep corrosion on lead free PCBs with morphology similar to that occurring in the field. The test conditions are listed in Table 1. The usefulness of the test was demonstrated by the finding that the mean time to failure of immersion silver (ImAg) finished boards was an order of magnitude less than that of organic surface preservative (OSP) finished boards, in agreement with the relative creep corrosion propensities of the two surface finishes in the field.

The next major work on MFG testing to be commonly cited in the literature was conducted at Alcatel-Lucent [Xu 2007]. As Table 1 shows, this was probably the first study to dramatically raise the concentration of H<sub>2</sub>S. The awareness that creep corrosion on Pb-free PCBs is highly surface sensitive was reported. [Xu 2007 and 2009]. The following general observations were made: PCBs with clean FR4 and clean solder mask surfaces were found not to support creep corrosion; organic acid wave soldering flux residues supported creep corrosion; rosin-based wave soldering fluxes and rosin-based solder paste are resistant to creep corrosion; and MFG testing provides a realistic accelerated test for creep corrosion. . Two recent papers by iNEMI [Fu 2012 and 2012] continued from the Alcatel-Lucent work and conducted a major study on four finishes: immersion silver (ImAg), electroless nickel-immersion gold (ENIG), lead-free hot air surface leveled (Pb-free HASL) and organic solderability preservative (OSP). Of these four finished, the Pb-free HASL was found to be the least prone to corrosion.

University of Maryland did extensive work developing MFG test method using various gas compositions and temperature and humidity test conditions [Zhang 2009, Zhang 2010]. One interesting observation coming out of the work was that a MFG test using single H<sub>2</sub>S gas can cause creep corrosion of PCBs. This is contrary to the general understanding that creep corrosion requires a synergy amongst various gases and may be surface contamination on PCBs.

Other tests for creep corrosion that have been researched are the Chavant clay test and the flowers of sulfur test. Mazurkiewicz was probably the first to observe and/or publish creep corrosion on PCBs exposed to sulfur-bearing gases in an automobile clay modeling design shop [Mazurkiewicz 2006]. Schueller published a copper creep corrosion test based on Chavant type J-525 modeling clay [Schueller 2007]. The PCBs under test were sealed in a container along with 2-4 pounds of wet clay. Sulfur gas was generated by heating the clay to approximately 50°C twice a day. Creep corrosion was typically visible on ImAg PCBs after 2 days and was quite pronounced after 5 days. Others, including Zhou at the University of Maryland, have used the clay test for the reliability assessment of PCBs [Zhou 2009]. The Chavant clay test has not become popular probably because the sulfur concentration in the air is difficult to control.

Modified versions of the flowers of sulfur (FOS) test based on ASTM B 809-95 (2008) have been used for testing the corrosion protection provided by conformal coatings [Hindin 2003] and for testing the corrosion resistance of miniature surface-mount resistors [Cole 2011]. The FOS test has also been successfully used to cause creep corrosion on PCBs [Kondos 2013]. The advantage of FOS testing is that air flow over the test PCBs and the temperature of the chamber are the only variables required to control the test. For every temperature, under equilibrium condition, there is a known, constant concentration of sulfur vapor (S<sub>8</sub>) in the air. The humidity, achieved by having a large surface area saturated salt solution in the chamber, is also controlled by temperature. The simplicity of control is a very attractive reason to study the use of FOS for the qualification of PCBs for resistance against creep corrosion. The focus of this paper is the design of a FOS chamber and its performance evaluation using copper and silver foils and the preliminary testing of the procedure using PCBs from a manufacturing lot known to have failed in service.

### **Role of fine dust on creep corrosion**

A survey of the quality of air associated with the occurrence of creep corrosion and the corrosion of surface mount resistors was conducted and published by ASHRAE in the 2011 white paper on particulate and gaseous contamination guidelines for data centers [ASHRAE 2011]. The paper concluded that for the aforementioned corruptions to occur, the copper and silver corrosion rates must be greater than 300 and 200 angstroms/month, respectively. Though the survey did not include temperature and humidity observations, in general most mission critical data centers do maintain the temperature and humidity well within the ASHRAE recommended limits of 18-27°C and relative humidity less than 60%. For corrosion products such as sulfides and/or for metallic ions to creep on PCB surfaces there must be an adsorbed moisture film on the surface forming an electrolytic path through which material transport can occur. But since a typical mission critical data center has well controlled and low relative humidity, for creep corrosion to occur, there must be dust with low deliquescent relative humidity settled on the PCB surface which can absorb moisture from the air and get wet even under low relative humidity conditions. It turns out that high levels of particulate contamination do occur along with high levels of gaseous pollution.

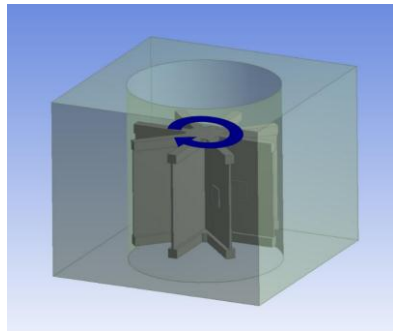

(a)

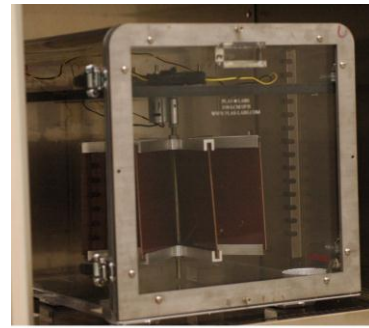

(b)

**Figure 1: (a) Schematic and (b) picture of paddle-wheel setup in FOS chamber**

Airborne dust in data centers can be characterized in to two size ranges: Coarse dust with particle size greater than  $2.5 \mu\text{m}$  and fine dust with particle size less than or equal to  $2.5 \mu\text{m}$ . Coarse dust is mainly from mineral sources. It is low in ionic salts, which makes it less corrosive, and it can be very effectively kept from entering data centers by common filtration practice. Fine dust is of particular concern because the water soluble ions represent a significantly greater fraction of its mass compared to coarse dust which has much lesser ionic content [Sinclair 1985]. The source of fine dust is both anthropogenic and natural. Nitrogen dioxide from automobile exhaust, ammonia from agriculture and sulfur dioxide from coal fired power plants can combine in the atmosphere possibly on submicron carbon particles to produce fine particles of ammonium sulfate, ammonium hydrogen sulfate and ammonium nitrate [Zhang 2004]. Of the three, ammonium hydrogen sulfate has the lowest deliquescent relative humidity (DRH) of 40% [Frankenthal 1993]. Depending on the composition, fine dust can have an effective DRH of 50-65% [Litvak]. In contrast, the effective DRH of most clean metal surface is in the range 70-80% [Frankenthal 1993]. Fine dust on surfaces can have three detrimental effects: (1) If the relative humidity in the room is above the DRH of the dust, the dust will get wet and support corrosion; (2) The increased surface area due to the fine dust will provide additional area on which gases can be adsorbed, thus increasing the rate of corrosion of the underlying metal; (3) Dust particles can increase the rate of corrosion through differential aeration. It has been suggested that in order to mimic the field conditions, especially those in the more polluted geographies, the qualification test for electronic devices should include both the influence of atmospheric particulate and gaseous contamination [Reid 2010].

A research addressing the contributions of both particulate and gaseous contamination was done at the AT&T Bells Labs [Frankenthal 1993]. In this research a novel but complicated means of generating submicron particles was described and it was concluded that the average acceleration factor from particle deposition was 100. The effect of fine dust on electronic hardware, without any contribution from gaseous contamination was studied by a team at the Lawrence Berkeley National Lab [Litvak 2000] using a novel means of generating fine ammonium sulfate particles and measuring the degradation of electrical surface insulation resistance as a function of relative humidity and voltage. The insulation resistance was found to decrease by several orders of magnitude with increasing relative humidity, even when the room humidity was below the DRH of the fine particles on the test circuit boards. Electrostatic forces were found to enhance the segregation of particles on the test circuit boards.

In summary, the direct effect of particulate contamination on hardware corrosion is the absorption of moisture by the fine dust particles especially when the room relative humidity is higher than the deliquescent relative humidity of the dust which

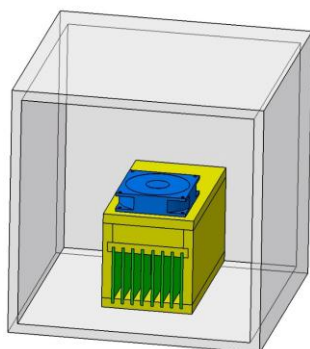

(a)

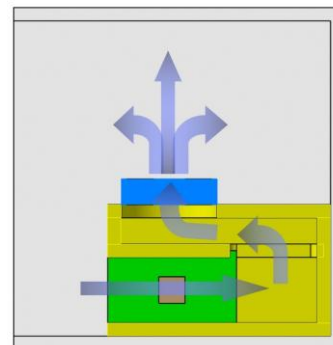

(b)

**Figure 2: Forced air setup. (a) Schematic of the setup; (b) Airflow pattern.**

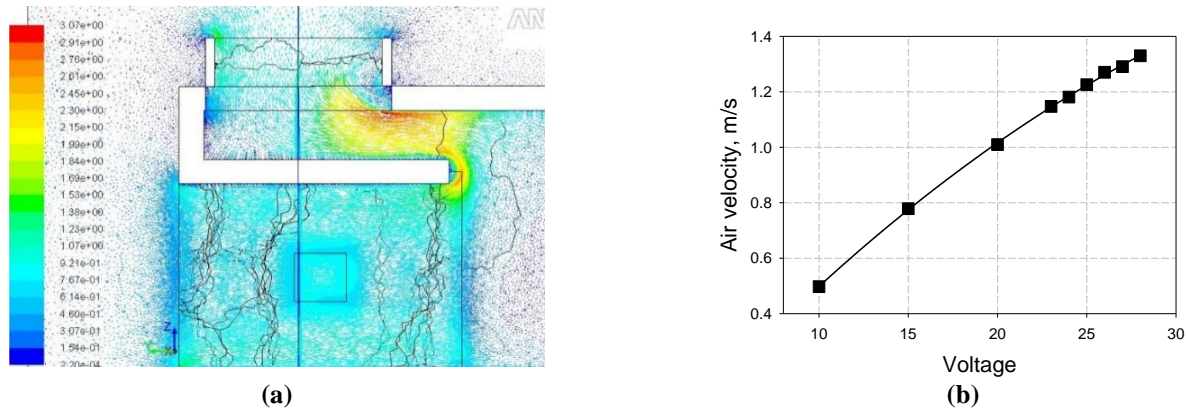

**Figure 3: (a) Forced air setup airflow pattern and (b) airflow velocity versus voltage applied to the blower. The air velocity versus voltage relationship was obtained for each forced air setup.**

for fine particles is in the range 50-65%. The fine dust chemical constituent of main concern is probably the ammonium hydrogen sulfate because of its low deliquescent relative humidity of 40%. The high ionic content of the settled fine particles provides the electrolytic path for the metallic ions and corrosion products to creep on the PCB surfaces. Particles can also contribute to degradation of hardware reliability two other ways: (1) Particles on metal surfaces may increase the rate of metal corrosion by differential aeration induced localized corrosion and (2) by increasing the surface area for gas adsorption.

### Experimental Setup and Procedure

The flowers of sulfur chamber is a 300-mm cube with a front-loading door sealed with a silicone coated rubber gasket. Humidity is maintained using a saturated salt solution contained in two beakers with 100-mm diameter. Sulfur concentration is maintained by sulfur contained in two beakers with 80-mm diameter. Temperature in the chamber is maintained at 60°C with as little a temperature fluctuations as possible. There are two approaches for mounting the test specimens in the chamber and for stirring the air: One uses a paddle wheel as shown in Figure 1, with 8 paddles, to mount the 8 test PCBs and move the air; the other is a forced air setup that uses a blower to draw the air over 8 stationary test PCBs, as shown in Figure 2.

The paddle wheel has a rotations per minute (RPM) limit of 25. The paddles do not move the air as readily as one's intuition might expect. At the maximum possible RPM, fluid flow simulation estimates the air velocity over the specimens is about 0.1 m/s. The air velocity over PCBs in computer racks is in the range 0.5-2 m/s. To achieve these higher airflow velocities, a new insert was designed and built, as shown in Figure 2. In this setup, a blower draws air from the front of the setup that has 8 test PCBs. The action of pulling the air up through the setup and having the air take a 180 degrees turn results in quite a uniform air flow across the 8 test PCBs as shown in Figure 3a. Air velocities of up to 2 m/s can be achieved. The air velocity is controlled by the RPM of the blower which in turn is controlled by the dc voltage input to its electric motor. Figure 3b shows a relationship of the air velocity over the PCB test specimens and the dc voltage applied to the blower motor. Figure 4 shows that in the paddle wheel setup, the temperature and humidity can reach steady state within ~2 hours. The time to achieve steady state in the forced air setup would be even shorter because of the higher air velocity in the chamber.

As mentioned in the previous section, it is probable that the necessary conditions for creep corrosion in data centers, with well controlled temperature and humidity conditions, may be the high levels of gaseous and particulate contamination. The

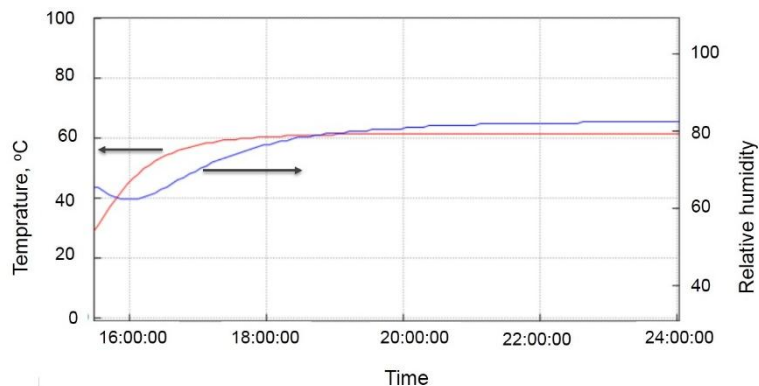

**Figure 4: The time for temperature and humidity to reach steady state in a FOS chamber with paddle-wheel setup.**

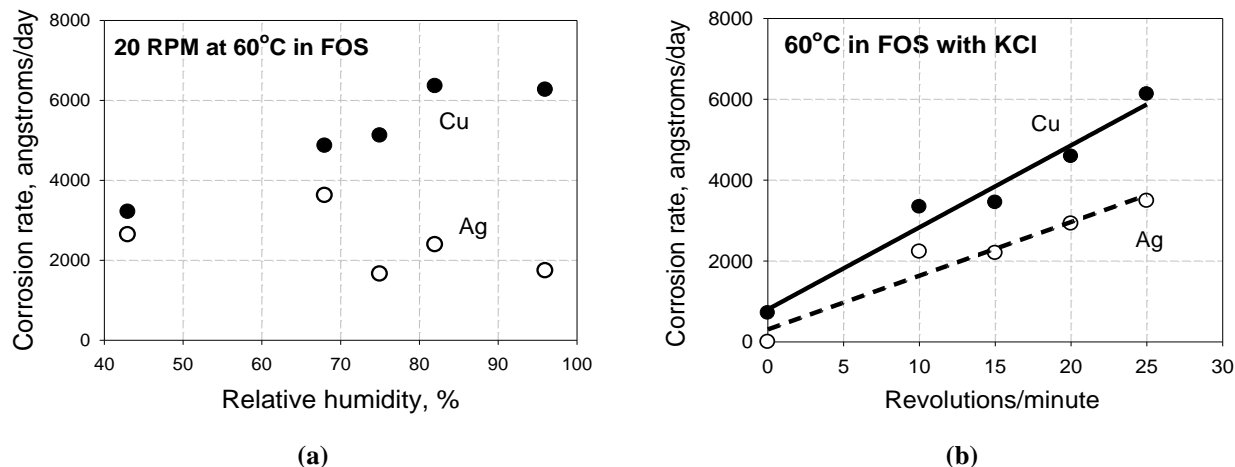

**Figure 5: Copper and silver corrosion rates in FOS chamber at 60°C with paddle-wheel setup (a) as a function of relative humidity at 20 RPM and (b) as a function of revolutions/minute at 80% relative humidity. The solid data points are for copper and the open data points are for silver corrosion rates. The corrosion rates were obtained using the weight gain method.**

most corrosive salt in fine dust is probably ammonium hydrogen sulfate because of its low deliquescent relative humidity of 40%. Besides the obvious need for reduced sulfur, the early and expansive work by Abbott pointed to the need for  $\text{NO}_x$  and  $\text{Cl}_2$ /chlorides in the environment to enhance copper corrosion rates. In our exploratory work, these two components were represented by ammonium nitrate and by NaCl in the form of dust. We covered the test PCBs with dust consisting of equal parts of  $(\text{NH}_4)_2\text{SO}_4$ ,  $\text{NH}_4\text{HSO}_4$ ,  $\text{NH}_4\text{NO}_3$  and NaCl before subjecting them to the FOS vapors in the test chamber.

The challenge was to devise a convenient way to apply a controlled amount of the dust uniformly distributed on the test PCB surfaces prior to stressing the PCBs in the FOS chamber. The objective was to achieve 10-500  $\mu\text{g}/\text{cm}^2$  total salt concentration on the test PCB surfaces. The procedure explored to spread the dust on the PCBs was to mix a solution of 25% by mass of each of the 4 salts,  $(\text{NH}_4)_2\text{SO}_4$ ,  $\text{NH}_4\text{HSO}_4$ ,  $\text{NH}_4\text{NO}_3$  and NaCl, pour a controlled amount of the aqueous solution on the test PCB and let the solution dry, leaving behind the salts on the PCB surface. Uniform distribution of salt could not be achieved because the water-PCB surface tension kept puddling up the water into large droplets, thus, concentrating the salt in the areas last to dry. We failed to achieve a uniform salt distribution across the complete PCB surface. So, instead, we decided to apply small droplets of the dilute salt solution locally on areas of interest on the PCBs. By controlling the volume of the drop,

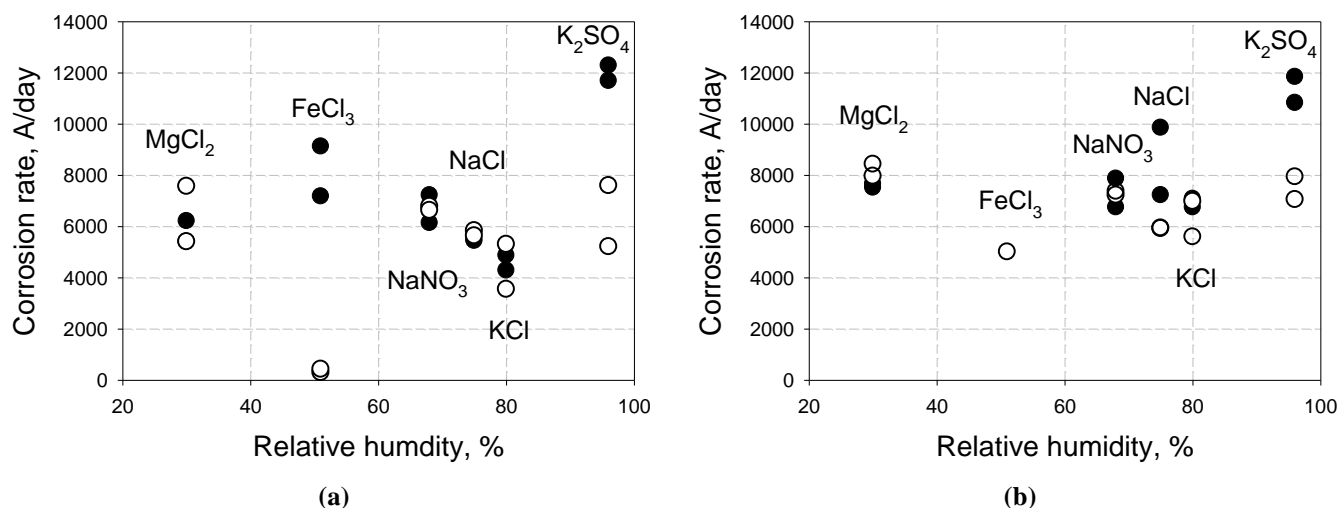

**Figure 6: Copper (solid circle) and silver (open circle) corrosion rates in angstroms/day as a function of relative humidity in FOS chamber with forced air setup at 60°C and 1 m/s air flow. Corrosion rates of figure (a) were obtained by the coulometric reduction method. Corrosion rates of figure (b) were obtained on the same foils using the weight gain method.**

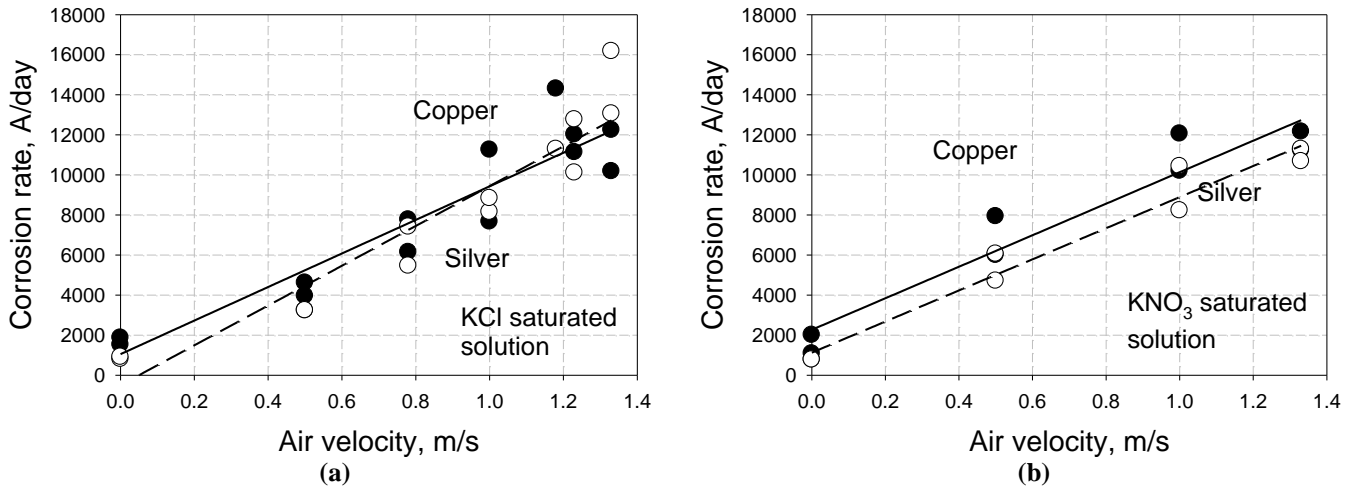

**Figure 7: Copper (solid circle) and silver (open circle) corrosion rates in angstroms/day as a function of air velocity in FOS chamber with the forced air setup at 60°C at (a) 80% relative humidity using KCl saturated solution and at (b) 82% relative humidity using KNO<sub>3</sub> saturated salt solution. The corrosion rates were obtained using the weight gain method.**

the wetted surface area and the salt solution concentration, we could achieve the desired salt concentration locally, explained as follows: A dilute solution of 0.125 g each of (NH<sub>4</sub>)<sub>2</sub>SO<sub>4</sub>, NH<sub>4</sub>HSO<sub>4</sub>, NH<sub>4</sub>NO<sub>3</sub> and NaCl in 100 ml de-ionized water was dropped on selected areas of a PCB using a glass pipette. Each drop was about 4 mm in diameter and about 2 mm high. When a droplet dried over a 4-mm diameter area, it left an average total salt concentration of about 500 mg/cm<sup>2</sup>. Since the salt contamination is applied locally on a PCB, the locations of application must be carefully noted for future reference. One advantage of this approach is that salts with many different surface concentrations can be deposited and simultaneously studied on a test PCB. For example, one can deposit, say, 10 drops of 10 different salt concentrations. Thus, one can study the effect of 10 different salt concentrations simultaneously on one test PCB.

The amount of salt on a surface can be determined by extracting the salt in de-ionized water and measuring the increase in the electrical conductivity of the water. The deliquescent relative humidity of a dust can be determined by covering inter-digitated comb coupons (SIR test board, IPC-B24 Rev A) with the dust and applying 10 V across the combs, separated by 0.5 mm spacing, and measuring the leakage current while raising the relative humidity in a step wise or linear manner. Figure 8a shows the current leakage as a function of time at various humidity levels for the ammonium salt and NaCl solution described earlier. The same data are plotted in Figure 8b as leakage current versus relative humidity. Note that the leakage current was in the pico-Ampere range when the humidity was 50% and spiked up when the relative humidity was raised to 62%. The deliquescent relative humidity of this dust is somewhere between 50 and 62%. The reason for the rise in current at 62% relative humidity is the absorption of moisture by the dust; and the reason for the fall is probably the depletion of the mobile

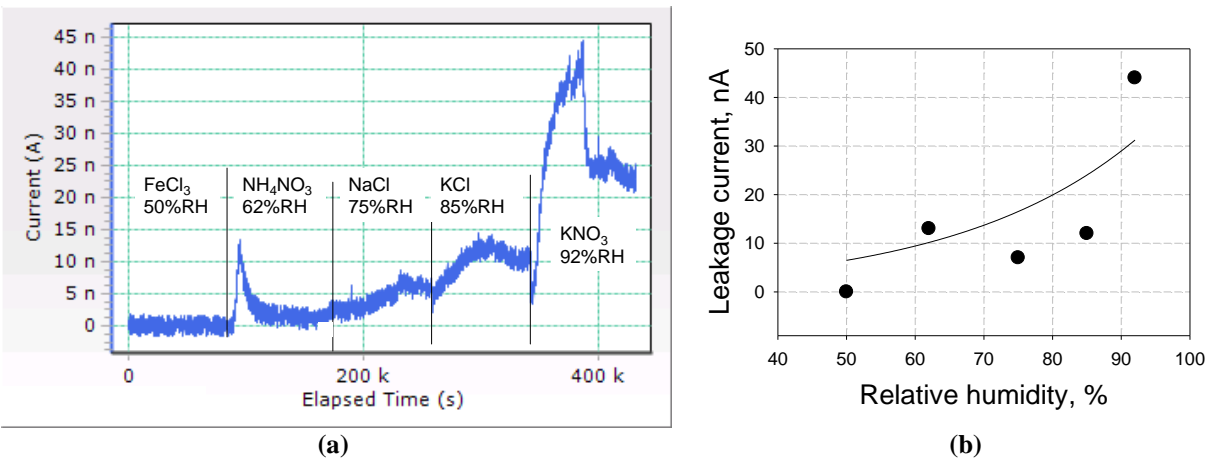

**Figure 8: (a) Leakage current across inter-digitated comb coupons with 0.5-mm spacing with the salt covering the combs consisting of equal parts of (NH<sub>4</sub>)<sub>2</sub>SO<sub>4</sub>, NH<sub>4</sub>HSO<sub>4</sub>, NH<sub>4</sub>NO<sub>3</sub> and NaCl. (b) The data of figure (a) are plotted as the peak leakage current versus relative humidity.**

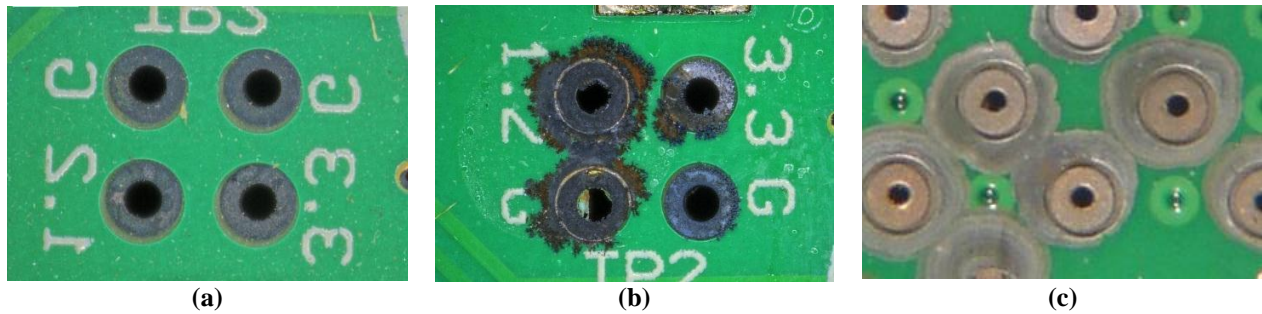

**Figure 9: Results of 3 days exposure of PCBs in a FOS chamber with forced air setup at 60°C and 82% relative humidity, using a  $\text{KNO}_3$  saturated salt solution, at 1 m/s air velocity. The PCBs are from a manufacturing lot that suffered creep corrosion in polluted geographies: (a) as received from stock; (b) contaminated with  $(\text{NH}_4)_2\text{SO}_4$ ,  $\text{NH}_4\text{HSO}_4$ ,  $\text{NH}_4\text{NO}_3$  and  $\text{NaCl}$  each with  $125 \mu\text{g}/\text{cm}^2$  concentration level; (c) this PCB suffered creep corrosion in the field.**

charge needed for the leakage current flow.

The FOS test was started by first inserting the two saturated salt solution beakers in the chamber and bringing the humidity to equilibrium at 60°C. The test specimens were then installed and after a soak time of 15-30 minutes, to ensure the specimens have reached the chamber temperature, the two beakers containing the sulfur are inserted into the chamber. The sulfur temperature must be lower than that of all other surfaces in the chamber; if not, there will be sulfur transfer from the sulfur beaker to the surface at the lower temperature. At the very least, the temperature of the specimens under test must be higher than the sulfur temperature.

The effect of air velocity and humidity on copper and silver corrosion rates was conducted on metal foils prepared as follows: Metal foils, 2.5.4x51-mm in area and 0.13-mm thick, were degreased in iso-propyl alcohol and abraded with 600 grit metallographic grinding paper under de-ionized water. The foils were then rinsed with de-ionized water and iso-propyl alcohol and blown dried using oil-free compressed nitrogen.

No special treatment was done on the PCB specimens that were tested in this study except for the local application of controlled concentration of dust, containing the ammonium salts and  $\text{NaCl}$ , on some of the PCBs.

### Results and Discussion

The rates of corrosion of copper and silver foils mounted on paddle wheels rotating at 20 RPM in the flowers of sulfur chamber at 60°C were measured as a function of relative humidity using the weight gain method. Appendices I and II explain how one can calculate the corrosion product thickness from the gain in weight. The relative humidities were obtained using various saturated salt solutions. The air velocity over the metal foils was less than 0.1m/s. The duration of the test was 24 hours. The results plotted in Figure 5a show that the copper and the silver corrosion rates have a somewhat step-wise increase above about 80% relative humidity. Further work is needed to verify this behavior.

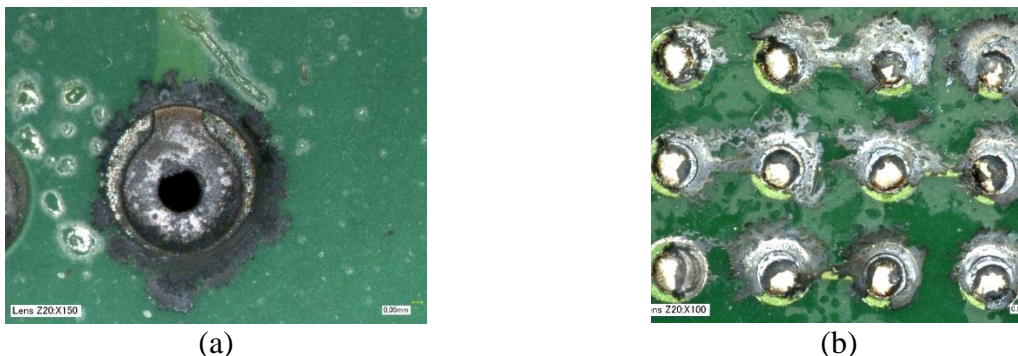

**Figure 10: The above photographs show result of 8 days exposure of PCBs in FOS chamber with a paddle-wheel setup rotating at 20 RPM, at 60°C and 82% relative humidity using a  $\text{KNO}_3$  saturated salt solution. (a) PCB is from a lot that suffered creep corrosion in polluted geographies and is covered with  $35 \mu\text{g ZnCl}_2/\text{cm}^2$ ; (b) PCB is an ImAg finished board soldered using organic acid flux and covered with  $70 \mu\text{g ZnCl}_2/\text{cm}^2$ .**



The paddle-wheel setup was also used to determine the effect of paddle wheel RPM on the rates of corrosion of copper and silver foils mounted on the paddles. The relative humidity was controlled at 80% in the 60°C chamber using KCl saturated salt solution. The corrosion rates were measured using the weight gain method and are plotted in Figure 5b as a function of the paddle wheel RPM. The corrosion rates increased quite linearly with the paddle wheel RPM. It is expected that the curve would reach a plateau at some point as the RPM is raised. However, as the RPM was limited to about 25, the plateau was not reached.

The somewhat step-wise increase in corrosion rate at ~80% relative humidity, seen in the paddle-wheel setup, was not observed in the forced air setup in which the air velocities over the foils were much higher. Corrosion rate tests were run in the forced air flow of sulfur setup at 60°C and 1 m/s air velocity over the metal foils. As shown in Figure 6, humidity had no well-defined influence on the copper and silver corrosion rates. Figure 6a reports corrosion rates determined by the coulometric reduction method and Figure 6b by the weight gain method.

The effect of air velocity on copper and silver corrosion rates, at 80% relative humidity using KCl saturated salt solution and at 82% relative humidity using KNO<sub>3</sub> saturated salt solution, was studied in a forced air flow of sulfur chamber at 60°C. The relationship was quite linear for both the metals, as shown in Figure 7, with no sign of the corrosion rates plateauing off even at velocities as high as 1.3 m/s. In future work, we will extend the study to air velocities as high as 2 m/s.

The above works shows that in the relative humidity range of interest, which is 75-90%, and with a reasonable air velocity of ~1m/s, the copper and silver corrosion rates of 5000-10000 angstroms/day compare well with those expected in the MFG testing done earlier by iNEMI and other researchers.

The proof of an effective creep corrosion qualification test lies in its ability to discern between PCBs that will fail in the field and those that will not. A single-corrodent FOS test lacks the synergistic effects of various gaseous contaminants and fine dust that PCBs encounter in service. To include the effects of NO<sub>x</sub> and Cl<sub>2</sub>/chlorides and those of ammonium-salt containing fine dust, an ImAg-finished PCB from a lot with known field history of high propensity to creep corrosion, was locally contaminated with controlled amounts of four salts ((NH<sub>4</sub>)<sub>2</sub>SO<sub>4</sub>, NH<sub>4</sub>HSO<sub>4</sub>, NH<sub>4</sub>NO<sub>3</sub> and NaCl) as explained in the earlier section. A PCB from the same lot, used as a control card, was not contaminated with the dust. The two PCBs were subjected to FOS vapors at 60°C, 82% relative humidity using KNO<sub>3</sub> saturated salt solution, and 1 m/s air velocity. After 3 days of stressing, the PCBs were optically examined at low magnification. Figure 9a shows the non-contaminated PCB to have heavy corrosion of the copper pads, but no creep corrosion. Figure 9b shows extensive creep corrosion in the local areas contaminated with the ammonium and NaCl salts. The morphology of this creep corrosion is quite similar to that seen on the failed cards returned from the field (Figure 9c). A card from the same manufacturing lot was contaminated with ZnCl<sub>2</sub>, which is known to occur in some data centers with high chloride levels and extensive use of zinc plated air ducting. Figure 10a shows creep corrosion occurring in FOS chamber in a few days at 60°C and 82% relative humidity. Figure 10b shows an ImAg finished card soldered with organic acid flux and contaminated with 75 μg ZnCl<sub>2</sub>/cm<sup>2</sup> suffered creep corrosion when subjected to the same FOS conditions as the card in Figure 10a.

It is clear that salt contamination promoted creep corrosion. A two-fold challenge remains for future work: What is the lowest concentration of salts necessary for creep corrosion and will PCBs from reliable lots, free of creep corrosion in service, survive the FOS test even when contaminated with salts?

## Conclusion

The following conclusions can be drawn from the present phase of the iNEMI project on developing a cost-effective qualification test for creep corrosion on PCBs:

- In the flow of sulfur (FOS) test at 60°C, at low air velocities less than 0.1 m/s, copper corrosion rate was lower in the lower humidity range, rising in a somewhat step-wise manner to a higher corrosion rate above about 80% relative humidity. The silver corrosion rate remained quite independent of relative humidity. At the higher air velocity of 1 m/s, the corrosion rates did not behave in as well-defined a manner as a function of humidity.
- In the flow of sulfur (FOS) test at 60°C and 80-82% relative humidity, the copper and silver corrosion rates increased quite linearly with air velocity with no sign of plateauing off even at velocity as high as 1.3 m/s.
- A means was developed to locally apply controlled concentrations of salts to PCBs prior to subjecting them to the FOS test.
- The presence of salt contamination, similar in composition to the fine dust (PM<sub>2.5</sub>), was found to be necessary for creep corrosion. PCBs from lots with history of creep corrosion related failures, did not suffer creep corrosion in FOS test unless contaminated with ammonium salts and NaCl. ZnCl<sub>2</sub> salt, found in some data centers high in chlorides and with extensive zinc plated ducting, was also found to aid in creep corrosion on PCBs from lots known to suffer creep corrosion in the field.

## References

- Abbott, W.H. 1986. Studies of natural and laboratory environmental reactions on materials and components, Environmental Studies Group, Battelle, Columbus, OH 43201.
- Abbott, W.H. 1988. The Development and Performance Characteristics of Mixed Flowing Gas Test Environment, IEEE Trans. On Component, Hybrids, and Mfg., Tech., vol. 11, No.1, March 1988, pg. 22-35
- ASHARE. 2011. 2011 Gaseous and Particulate Guidelines for Data Centers, Atlanta, GA, USA.
- ASTM B 809-95. 2008. Standard Test Method for Porosity in Metallic Coatings by Humid Sulfur Vapor, ASTM International.
- Burnett W.H., F.S. Sandroff, and S.M. D'Egidio. 1992. Circuit Failure Due to Fine Mode Particulate Air Pollution, ISTFA '92, The 18<sup>th</sup> International Symposium for Testing & Failure Analysis, Los Angeles, CA, USA, 17-23 Oct 1992, pg 329-333.
- Cole, M., L. Hedlund, T. Kiraly, S. Nickel, P. Singh, T. Tofil. 2010. Harsh Environmental Impact on Resistor Reliability, SMTS Int'l Conf, Proc., 24 Oct 2010.
- Cullen, D., G. O'Brien. 2004. Implementation of immersion silver PCB finish in compliance with Underwriters Laboratories, IPC Printed Circuits Expo, 2004.
- EPA. 2013, The USA Environmental Protection Agency, <http://www.epa.gov/airtrends/aqtrnd95/no2.html>
- Frankenthal R.P., D.J. Siconolfi and J.D. Sinclair. 1993. Accelerated Life Testing of Electronic Devices by Atmospheric Particles: Why and How, J. Electrochem. Soc., vol. 140, no. 11, pg. 3129-3134, Nov 1993
- Fu, H., C. Chen, P. Singh, J. Zhang, A. Kurella, X. Chen, X. Jiang, J. Burlingame, S. Lee. 2012. Investigation of Factors that Influence Creep Corrosion on Printed Circuit Boards," SMTA Pan Pacific Microelectronics Symposium, Kauai, 14-16 Feb 2012.
- Fu, H., C. Chen, P. Singh, J. Zhang, A. Kurella, X. Chen, X. Jiang, J. Burlingame, S. Lee. 2012.. Investigation of Factors that Influence Creep Corrosion on Printed Circuit Boards, Part 2, SMTAI 2012
- Hindin, B., J. Fernandez. 2003. Testing of Conformal Coatings Using The Flowers of Sulfur Test, Tri-Service Corrosion Conference, 17-21 Nov 2003, Las Vegas, Nevada.
- Kondos, P. 2013. Private communications with P.A. Kondos.
- Krumbein S.J. 1989. Monitoring environmental tests by coulometric reduction of metallic control coupons, J, of Testing and Eval., vol 17, Issue 6, pages 357-367.
- Liang D., H.C.Allen, G.S. Frankel, Z.Y.Chen, R.G. Kelly, Y. Wu and B.E. Wyslouzil. 2010. Effects of Sodium, Chloride Particles, Ozone, UV and Relative Humidity on Atmospheric Corrosion of Silver, Journal of the Electrochemical Society, Vol. 157, No 4., pg. C146-C156, 2010
- Litvak, A., A.J. Gadgil, W.J. Fisk. 2000. Hygroscopic Fine Mode Particle Deposition on Electronic Circuits and Resulting Degradation of Circuit Performance: An Experimental Study, Indoor Air 2000, vol. 10, pg 47-56, 2000.
- New York State Department of Health. 2013. [http://www.health.ny.gov/environmental/chemicals/hydrogen\\_sulfide/](http://www.health.ny.gov/environmental/chemicals/hydrogen_sulfide/)
- Reid, M., L.F. Garfias Mesias. 2010. Understanding the Corrosion Mechanisms of Electronic Devices Subjected to Very Polluted Environments, Nace Corrosion 2010 Conference and Expo, Paper No. 10090, Houston, Texas.
- Rice D. W., Cappell R. J., Kinsolving W. and Laskowski J. J. 1980. *Indoor corrosion of metals*, J. Electrochem. Soc., pg.891-901, April 1980.
- Rice, D.W., P. Peterson, E.B. Rigby, P.B.P Phipps, R.J. Cappell and R. Tremoureux. 1981. Atmospheric Corrosion of Copper and Silver, J. Electrochem. Soc., ELECTROCHEMICAL SCIENCE AND TECHNOLOGY, vol. 128. Issue 2, pg. 275-284, Feb 1981.